

TG35/58-T

Printer version

User Manual



All rights reserved. Total or even partial reproduction of this manual in any form, whether on paper or electronically, is strictly forbidden. While CUSTOM ENGINEERING SPA guarantees that the information contained in this manual has been carefully checked and verified, CUSTOM ENGINEERING SPA and other resources utilized in its creation assume no responsibility for situations arising from its use.

Feedback regarding any errors in the manual's content or suggestions on how it could be improved would be greatly appreciated. Since its products are subject to continuous checking and improvement, CUSTOM ENGINEERING SPA reserves the right to modify the information contained in this manual without prior notice.

COD. DOME - TG35-58-T

VERS. 1.33



A.u.S. Spielgeräte GesmbH
Scheydgasse 48 A-1210 Wien
Tel. +43-1-271 66 00 Fax. +43-1-271 66 00 75
E-mail: verkauf@aus.at
<http://www.aus.at> <http://www.garlando.at>
Öffnungszeiten: Mo-Do 9-18 und Fr. 9-17 Uhr

PRINTER COMPONENTS

A. TG35/58-T - exterior view

- 1- Printing mechanism
- 2- Report "Key"
- 3- Feed "Key"
- 4- Paper roll support
- 5- Case
- 6- Front panel
- 7- Led
- 8- Paper output

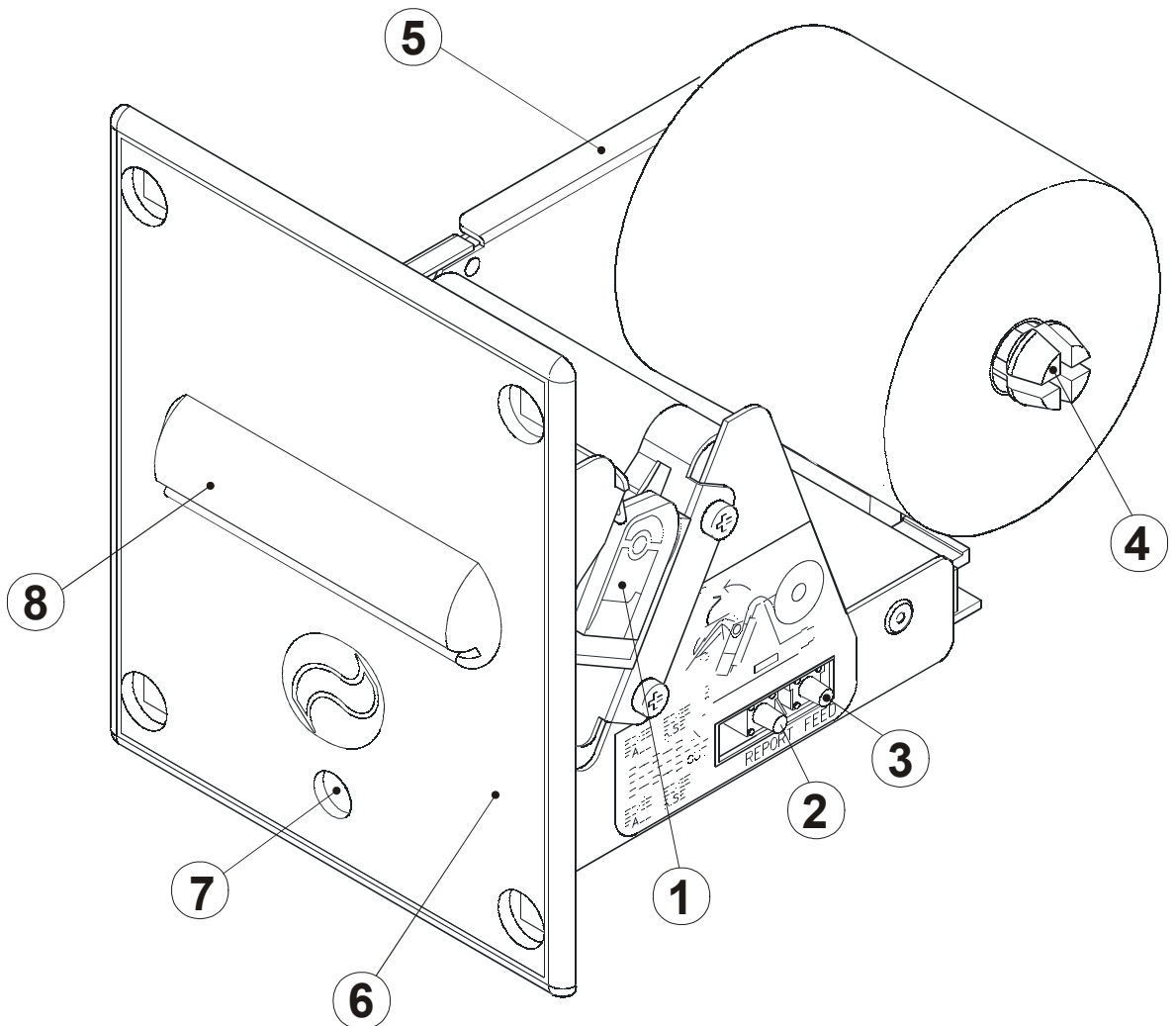

B. TG35/58-T - rear view

- 1- Power supply connector
- 2- Power supply connector and additional signals
- 3- TTL serial interface connector

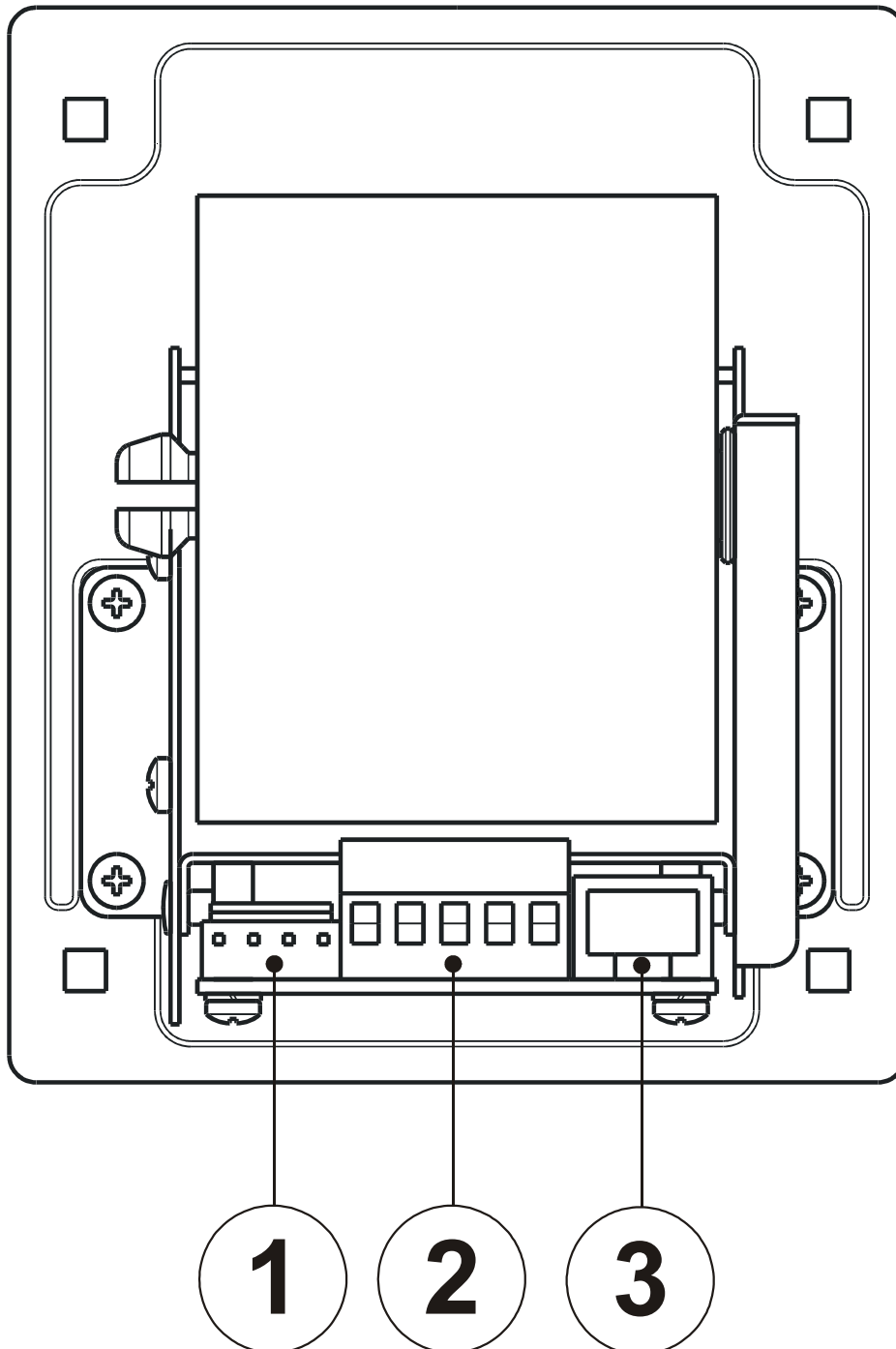

TABLE OF CONTENTS

INTRODUCTION

MANUAL ORGANIZATION	1
SYMBOLS USED IN THE MANUAL.....	1
GENERAL SAFETY INFORMATION	1
UNPACKING THE PRINTER	2
MAIN CHARACTERISTICS	2
PRINTER DESCRIPTION	3

1. INSTALLATION AND OPERATION

1.1 CONNECTIONS	1-1
1.1.1 Power supply and Input/Output	1-1
1.2 SETUP	1-2
1.2.1 Configuration of REPORT and FEED keys	1-3
1.3 AUTOTEST	1-3
1.4 CAUTIONS	1-3
1.5 MAINTENANCE.....	1-4
1.5.1 Using the control discs	1-4
1.5.2 Changing the paper roll	1-4

2. INTERFACES

2.1 TTL SERIAL	2-1
----------------------	-----

3. PRINTER FUNCTIONS

3.1 COMMAND DESCRIPTIONS	3-1
3.1.1 ESC/POS Emulation	3-1

4. TECHNICAL DATA

4.1 TECHNICAL DATA.....	4-1
4.2 DIMENSIONS	4-2

APPENDIX A - ACCESSORIES AND SPARE PARTS

A.1 ACCESSORIES	A-1
A.1.1 Power supply	A-1
A.1.2 RS232 cable adaptation	A-2
A.2 SPARE PARTS	A-5

MANUAL ORGANIZATION

In addition to the Introduction which contains information regarding the symbols used in the manual, general safety information, instructions for unpacking the printer and a brief description and main characteristics of the machine, this manual is divided into the following chapters:

Chapter 1: Contains the information required for correct printer installation and use

Chapter 2: Contains interface data

Chapter 3: Contains a description of printer controls

Chapter 4: Contains printer technical data

Chapter 5: Contains the character sets (fonts) used by the printer

SYMBOLS USED IN THE MANUAL



NOTE

Gives important information or suggestions for printer use.



WARNING

Information indicated by this symbol must be followed carefully to avoid damaging the printer.



DANGER

Information indicated by this symbol must be followed carefully to avoid damage or operator injury.

GENERAL SAFETY INFORMATION

- Read and retain the instructions which follow.
- Before cleaning the printer, be sure to pull out the electrical cable.
- Use a damp cloth to clean the printer. Do not use liquid or spray products.
- Do not operate the printer near water.
- When positioning the printer, make sure its cables will not be damaged.
- Use the type of electrical power supply indicated on the printer label. If uncertain, contact your dealer.
- Do not block the ventilation openings.

- Do not insert objects inside the printer as this could cause short-circuiting or damage components that could jeopardize printer functioning.
- Do not spill liquids onto the machine.
- Do not carry out repairs on the machine yourself, except for the normal maintenance operations given in the user manual.
- Unplug the printer from the electrical mains and call a specialized repairman if any of the following conditions should arise:
 - A. the power supply connector is damaged
 - B. liquid has spilled into the printer
 - C. the printer has been exposed to rain or water
 - D. the printer is not functioning normally despite the fact that all instructions given in the user manual have been followed
 - E. the printer has been dropped and the cover is damaged
 - F. printer performance is noticeably reduced
 - G. the printer is not working

UNPACKING THE PRINTER

Remove the printer from the carton, taking care not to damage the packing materials which should be retained for future shipping/moving.

Make sure all components listed below are present and not damaged. If any part is missing and/or damaged, contact customer service.

1. Manual (or CD-rom)
2. Printer
3. Discs control of paper roll

MAIN CHARACTERISTICS

The TG35/58-T printer is the ideal solution for :

- Gaming machines
- Vending machines
- Self-service machines
- Paper tear-off and anti-paper jam system.
- Optional RS232 cable adaptation.

PRINTER DESCRIPTION

It is equipped with a 200 dpi thermal print mechanism that uses paper with a width of 35/58 mm; it has a TTL serial interface (optional RS232 cable) and is also equipped with a calendar clock (Real Time Clock).

The TG35/58-T printer consists of a case (5) onto which the following components are fitted: thermal print mechanism (1), paper roll pin (4) front panel (6) in PPO for installation on Gaming/Vending Machines.

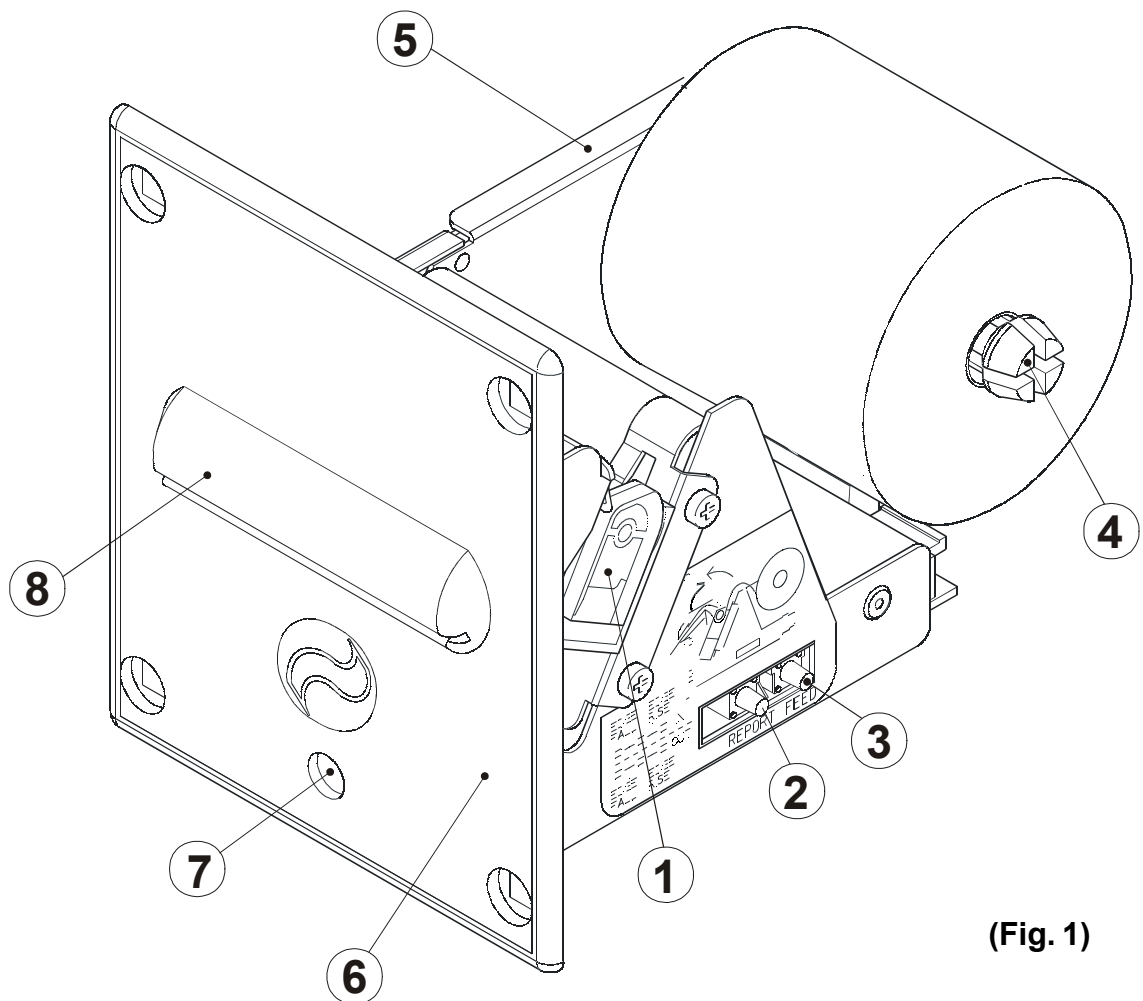

(Fig. 1)

- When the “REPORT” key (2) is pressed, it prints the printer operational report.
- When the “FEED” key (3) is pressed, the paper can be fed forward manually.

- The red Status LED (7) displays a printer hardware error status and the winnings. The check is carried out“on line”, i.e. in the event of a malfunctioning, the LED will starts flashing as follows:

(Tab.1)

STATUS LED	DESCRIPTION
Always OFF	Printer OFF
Always ON	Printer ON – no faults
Slow flashing (on for a long period)	Tilting cover raised
Slow flashing (on for a short period)	Paper Out Message

1. INSTALLATION AND OPERATION

1.1 CONNECTIONS

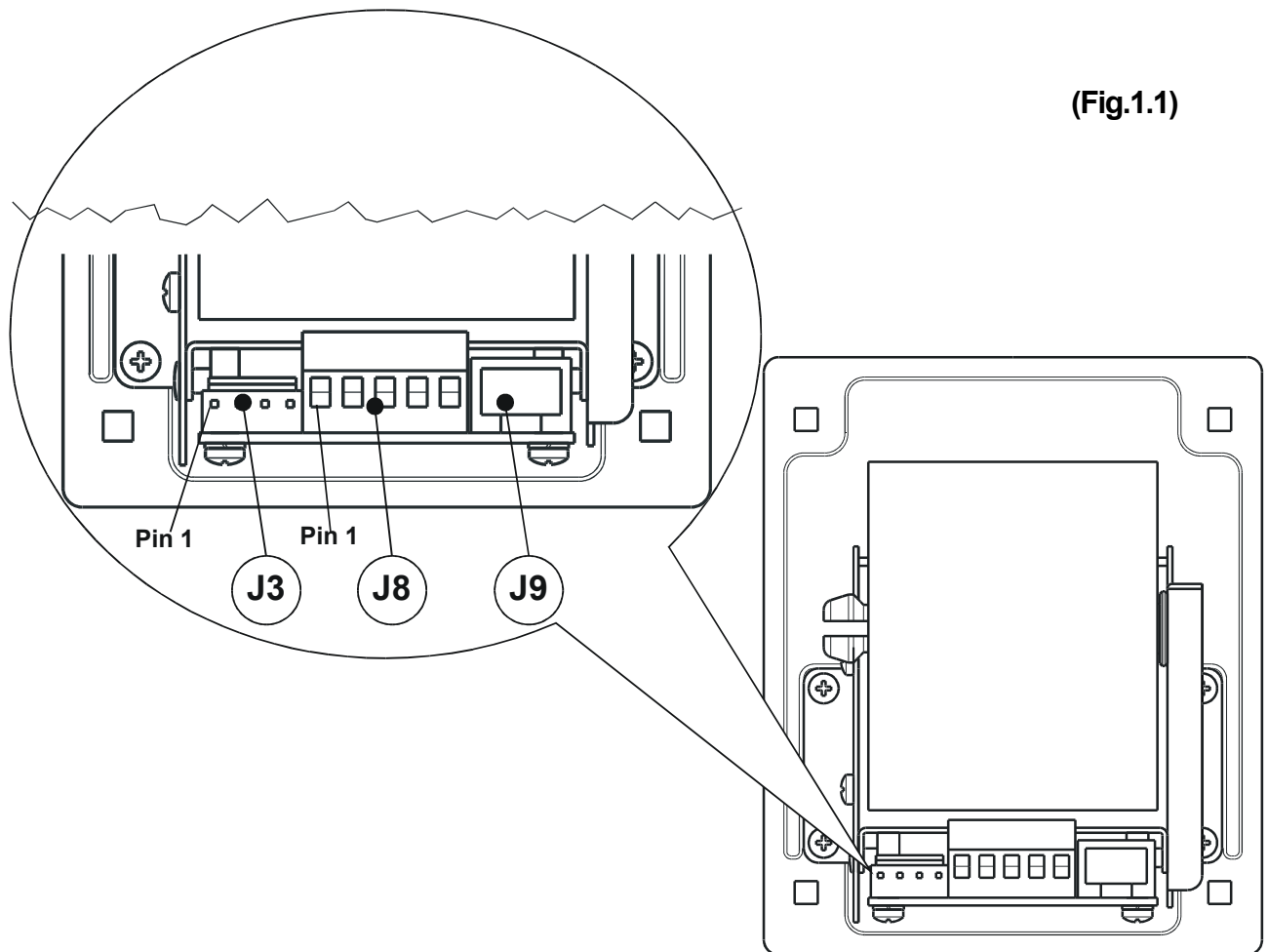

(Fig.1.1)

1.1.1 Power supply and Input/Output

As regards the power supply, the printer TG35/58-T is equipped with a Ticket Outlet-compatible 4-pin male connector (J3). The signals on the pins of the feed connector are as follows:

PIN	SIGNAL	< IN / OUT >	DESCRIPTION
1	N.C.	-	Not connected
2	+ 12 V	POWER	POWER
3	GND	POWER	POWER
4	N.C.	-	Not connected

(Tab.1.1)



WARNING:

Be sure to observe the correct polarity for the power supply.

1. INSTALLATION AND OPERATION

As regards the power supply and additional signals, the TG35/58-T printer is equipped with a 5-pin screw terminal connector (J8). The signals on the connector pins are as follows:

(Tab.1.2)

PIN	SIGNAL	< IN / OUT >	DESCRIPTION
1	+12 V	POWER	POWER
2	GND	POWER	POWER
3	AUXILIARY INPUT A	IN (O.C.)	OPEN COLLECTOR
4	AUXILIARY INPUT B	IN (O.C.)	OPEN COLLECTOR
5	AUXILIARY OUTPUT	OUT (O.C.)	OPEN COLLECTOR

1.2 SETUP

The printer enables the configuration of the printer default parameters. The parameters affected during configuration are:

- **Input level** ⁽¹⁾ : Negative^D.
- **Output level** ⁽¹⁾ : Negative^D.
- **Sens. Inceppamento** : Enabled^D, Disabled.
- **Speed/Current**: Low^D, Normal, High.
- **Print Density** : Very light, Light, Normal^D, Dark, Very dark, Double copy
- **Ticket** ⁽¹⁾ : Cumulative^D
- **Valore Coin in** ⁽¹⁾: 1^D
- **Valore Note in** ⁽¹⁾ : 1^D

Notes : The parameters indicates with a ^D symbol are the default values.



⁽¹⁾ **NOTE** : The parameters indicates are not used.

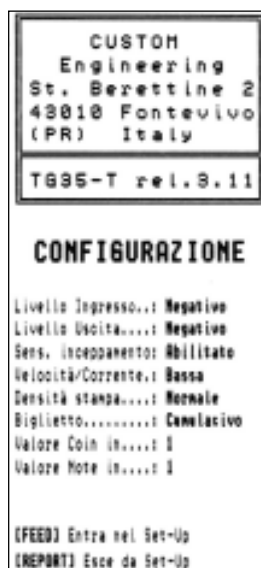

(Fig.1.2)

1. INSTALLATION AND OPERATION

1.2.1 Configuration of REPORT and FEED keys

If, when the printer is switched on, both of the above-mentioned keys are held down, the printer enters configuration mode and prints the first modifiable parameter.

At this point, each time the REPORT key is pressed, the parameter changes and its current value is printed.

Once the desired value has been obtained, press the FEED key to proceed to the next parameter, and so on.

Once all the parameters have been run through, the printing of a message signals the end of setting procedure.

1.3 AUTOTEST

To run the autotest, press the **FEED** key while switching on the printer. During the running of the autotest, the character fonts and logos stored inside the printer are printed.

1.4 CAUTIONS



WARNINGS:

- Do not print without paper.
- Do not drag the carriage manually when the printer is on.
- Do not allow any foreign bodies to become trapped inside the printer.
- Safeguard all parts of the printer from blows, both during and subsequent to installation.

1.5 MAINTENANCE

1.5.1 Using the control discs

Assembly the control discs with the paper roll as shown in the fig. 1.3.

(Fig.1.3)

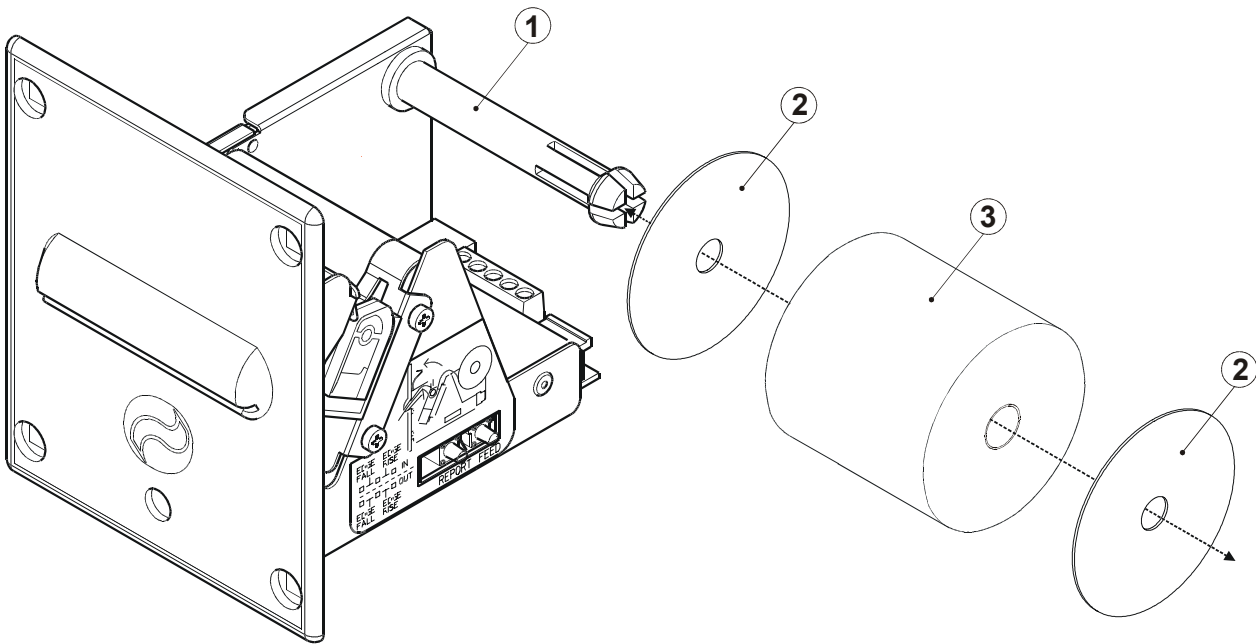

1.5.2 Changing the paper roll

To change the paper roll in the printer, proceed as follows (see the fig. 1.4) :

- 1) Position the paper roll (1), so that it rotates in the direction shown (fig.1.4);
- 2) Insert the end of the paper roll in the print mechanism (2) and wait until the roll loads automatically;
- 3) Remove the ticket from the mouth paper output;

1. INSTALLATION AND OPERATION

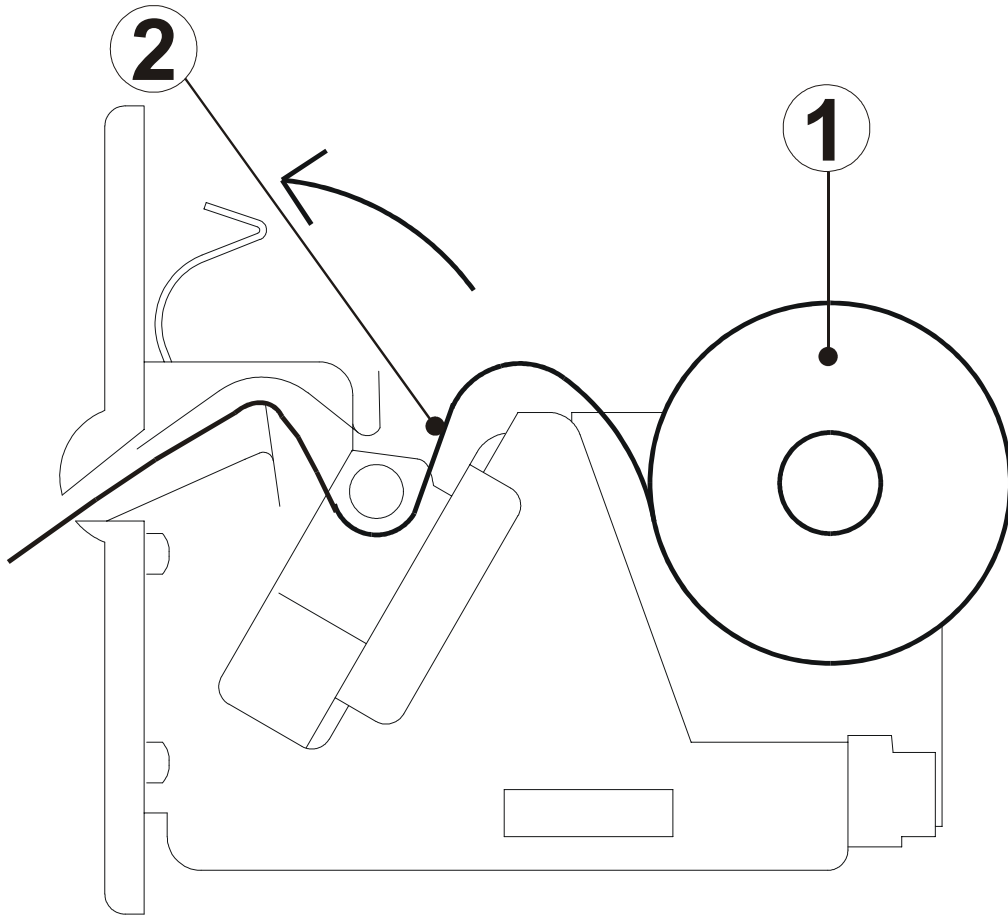

(Fig.1.4)

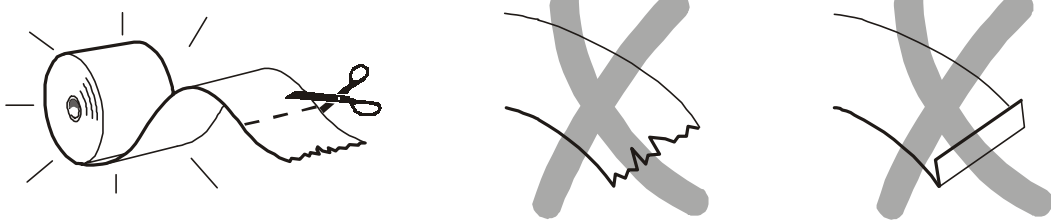

WARNING

Before inserting the paper, ensure that it is cut evenly.

(Fig.1.5)

2. INTERFACES

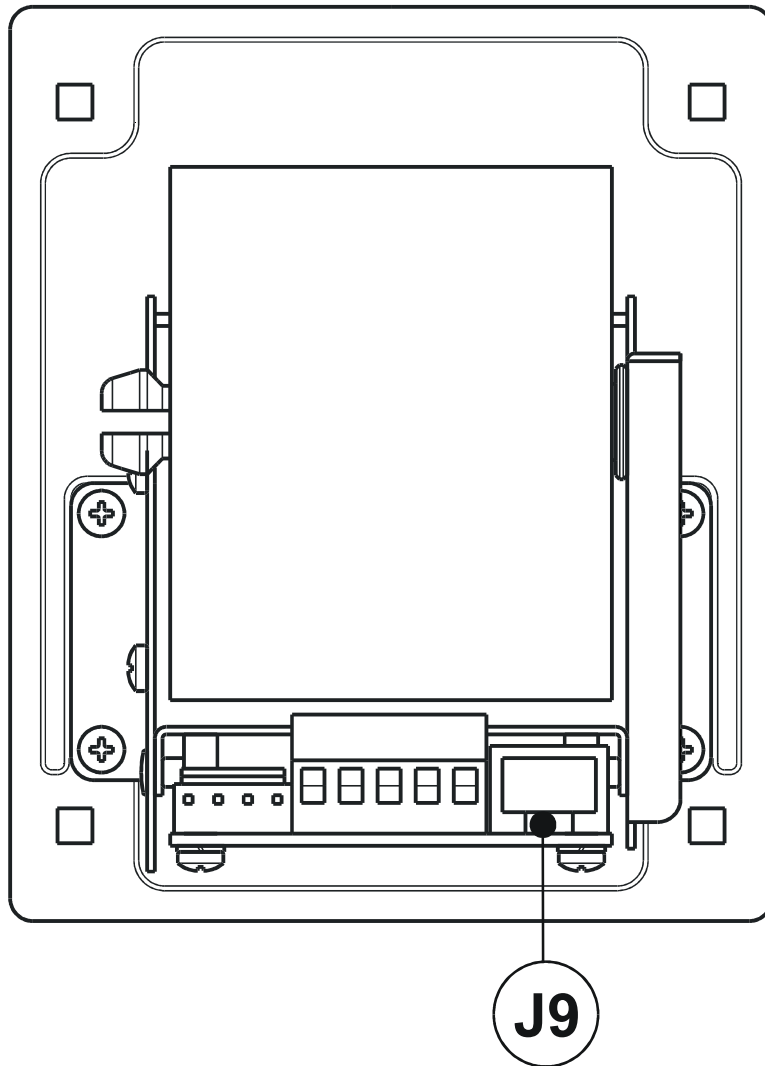

(Fig.2.1)

2.1 TTL SERIAL

The printer has a TTL serial interface and is connected by means of a RJ45 connector J9 (see fig. 2.1). In the following table, the signals present on the connector are listed:

PIN	SIGNAL	IN / OUT	DESCRIPTION
1	VCC	OUT	+ 5V
2	GND	-	GROUND
3	TXD	OUT	DATA TRANSMISSION
4	RXD	IN	DATA RECEPTION
5	RTS	OUT	READY TO SEND
6	+VIN	OUT	+ 12V
7	NC	-	NOT CONNECTED
8	NC	-	NOT CONNECTED

(Tab.2.1)

3. PRINTER FUNCTIONS

3.1 COMMAND DESCRIPTIONS

3.1.1 ESC/POS Emulation

The following table lists all the commands for function management in ESC/POS™ Emulation of the printer. The commands can be transmitted to the printer at any moment, but they will only be carried out when the commands ahead of them have been executed. The commands are carried out when the circular buffer is free to do so.

COMMAND DESCRIPTION TABLE

(Tab.3.1)

ASCII	HEX	Description
BS	\$08	Back space
HT	\$09	Horizontal tab
LF	\$0A	Print and line feed
CR	\$0D	Print and carriage return
DLE EOT n	\$10 \$04 (n)	Real-time status transmission
CAN	\$18	Cancel current line transmitted
ESC SP n	\$1B \$20 (n)	Set character right-side spacing
ESC ! n	\$1B \$21 (n)	Set print mode
ESC \$ nL nH	\$1B \$24 nL nH	Set absolute position
ESC (v nL nH	\$1B \$28 nL nH	Set relative vertical print position
ESC - n	\$1B \$2D (n)	Turn underline mode on/off
ESC 0	\$1B \$30	Select 1/8-inch line spacing
ESC 2	\$1B \$32	Select 1/6-inch line spacing
ESC 3 n	\$1B \$33 (n)	Set line spacing using minimum units
ESC 4 n	\$1B \$34 (n)	Set/reset script mode
ESC = n	\$1B \$3D (n)	Select device
ESC @	\$1B \$40	Initialize printer
ESC D n1...nk NUL	\$1B \$44 n1...nk 00	Set horizontal tab positions
ESC E n	\$1B \$45 (n)	Select emphasized mode
ESC G n	\$1B \$47 (n)	Select double-strike mode
ESC J n	\$1B \$4A (n)	Print and feed paper
ESC R n	\$1B \$52 (n)	Select international character set

3. PRINTER FUNCTIONS

ASCII	HEX	Description
ESC W	\$1B \$57	Print a graphic line
ESC \ nL nH	\$1B \$5C nL nH	Set relative print position
ESC a n	\$1B \$61 (n)	Select justification
ESC d n	\$1B \$64 (n)	Print and feed paper n lines
ESC r n	\$1B \$72 (n)	Set/reset red printing mode
ESC t n	\$1B \$74 (n)	Select character code table
ESC v	\$1B \$76	Transmit printer status
ESC x n	\$1B \$78 n	Select speed/current mode
ESC { n	\$1B \$7B (n)	Set/cancel upside-down character printing
ESC ⊥ n	\$1B \$C1 (n)	Set/cancel cpi mode
ESC · n xL xH yH yL	\$1B \$FA n xL xH yH yL	Print logo
GS B n	\$1D \$42 (n)	Turn white/black reverse printing mode on/off
GS I n	\$1D \$49 (n)	Transmit printer ID
GS L nL nH	\$1D \$4C nL nH	Set left margin
GS P x y	\$1D \$50 x y	Set horizontal and vertical motion units (mode 1)
GS W nL nH	\$1D \$57 nL nH	Set printing area width
GS Y n	\$1D \$59 n	Sets height in printing
GS Z n	\$1D \$5A n	Receive n bytes from serial port
GS r n	\$1D \$72 (n)	Transmit status
GS n	\$1D \$7C (n)	Set printing density

Given below are more detailed descriptions of each command.

BS

[Name] **Back space**

[Format] ASCII BS

Hex 08

Decimal 8

[Description] Moves print position to previous character.

3. PRINTER FUNCTIONS

[Notes] Can be used to put two characters at the same position.

[Default]

[Reference]

[Example]

HT

[Name] **Horizontal tab**

[Format] ASCII HT

Hex 09

Decimal 9

[Description] Moves the print position to the next horizontal tab position.

- [Notes]
- Ignored unless the next horizontal tab position has been set.
 - If the command is received when the printing position is at the right margin, the printer executes print buffer full printing and horizontal tab processing from the beginning of the next line.
 - Horizontal tab positions are set using ESC D.

[Default]

[Reference] **ESC D**

[Example]

LF

[Name] **Print and line feed**

[Format] ASCII LF

Hex 0A

Decimal 10

[Description] Prints the data in the buffer and feeds one line based on the current line spacing.

- [Notes]
- Sets the print position to the beginning of the line.

[Default]

[Reference] **ESC 2, ESC 3**

[Example]

CR

[Name]	Print and carriage return
[Format]	ASCII CR Hex 0D Decimal 13
[Description]	When autofeed is “CR enabled”, this command functions in the same way as LF , otherwise it is disregarded.
[Notes]	• Sets the print position to the beginning of the line.
[Default]	See “Autofeed in setup” parameter.
[Reference]	LF
[Example]	

DLE EOT n

[Name]	Real-time status transmission
[Format]	ASCII DLE EOT n Hex 10 04 n Decimal 16 4 n
[Range]	$1 \leq n \leq 4$
[Description]	Transmits the selected printer status specified by <i>n</i> in real time according to the following parameters: <i>n</i> = 1 transmit printer status <i>n</i> = 2 transmit off-line status <i>n</i> = 3 transmit error status <i>n</i> = 4 transmit paper roll sensor status <i>n</i> =1: Printer status

Bit	Off/On	Hex	Decimal	Function
0	Off	00	0	Not used. Fixed to Off.
1	Off	00	0	Not used. Fixed to Off.
2	Off	00	0	Not used. Fixed to Off.
3	Off	00	0	On-line.
	On	08	8	Off-line.
4	On	10	16	Not used. Fixed to On.
5	-	-	-	Undefined.
6	-	-	-	Undefined.
7	Off	00	0	Not used. Fixed to Off.

3. PRINTER FUNCTIONS

n=2: Off-line status

Bit	Off/On	Hex	Decimal	Function
0	Off	00	0	Not used. Fixed to Off.
1	Off	00	0	Not used. Fixed to Off.
2	Off	00	0	Not used. Fixed to Off.
3	Off	00	0	FEED button not pressed
	On	08	8	FEED button pressed
4	On	10	16	Not used. Fixed to On.
5	Off	00	0	Paper present.
	On	20	32	Paper end.
6	Off	00	0	No error.
	On	40	64	Error.
7	Off	00	0	Not used. Fixed to Off.

n=3: Error status

Bit	Off/On	Hex	Decimal	Function
0	Off	00	0	Not used. Fixed to Off.
1	On	02	2	Not used. Fixed to On.
2	Off	00	0	Not used. Fixed to Off.
3	-	-	-	Undefined.
4	On	10	16	Not used. Fixed to On.
5	Off	00	0	Not used. Fixed to Off.
6	Off	00	0	No auto-recoverable error.
	On	40	64	Auto-recoverable error.
7	Off	00	0	Not used. Fixed to Off

n=4: Paper roll sensor status

Bit	Off/On	Hex	Decimal	Function
0	Off	00	0	Not used. Fixed to Off.
1	On	02	2	Not used. Fixed to On.
2	Off	00	0	Not used. Fixed to Off.
3	Off	00	0	Not used. Fixed to Off.
4	On	10	16	Not used. Fixed to On.
5, 6	On	60	96	Fixed to On. The paper end is detected by the sensor
7	Off	00	0	Not used. Fixed to Off.

[Notes]

- This command is executed when the data buffer is full.

- This status is transmitted whenever data sequence 10H 04H n is received.
- After the paper autoloader all buffers (receive and print) are cleared.

[Default]

[Reference] See tables below.

[Example]

CAN

[Name] **Cancel current line transmitted**

[Format] ASCII CAN
Hex 18
Decimal 24

[Description] Deletes current line transmitted.

- [Notes]
- Sets the print position to the beginning of the line.
 - However, this command does not clear the receive buffer.

[Default]

[Reference]

[Example]

ESC SP n

[Name] **Set right-side character spacing**

[Format] ASCII ESC SP n
Hex 1B 20 n
Decimal 27 32 n

[Range] $0 \leq n \leq 255$

[Description] Sets the character spacing for the right side of the character to [n x horizontal or vertical motion units].

- [Notes]
- The right character spacing for double-width mode is twice the normal value.
- When the characters are enlarged, the right side character spacing is m (2 or 4) times the normal value.
- The horizontal and vertical motion units are specified by **GS P**. Changing the horizontal or vertical motion units does not affect the current right side spacing.

3. PRINTER FUNCTIONS

- The **GS P** command can change the horizontal (and vertical) motion unit. However, the value cannot be less than the minimum horizontal movement amount.
- In standard mode, the horizontal motion unit is used.
- The maximum right side spacing is 255/200 inches.

[Default] n = 0
 [Reference] **GS P**
 [Example]

ESC ! n

[Name] **Select print modes**
 [Format] ASCII ESC ! n
 Hex 1B 21 n
 Decimal 27 33 n
 [Range] $0 \leq n \leq 255$
 [Description] Selects print modes using *n* (see table below):

Bit	Off/On	Hex	Decimal	Function
0	-	-	-	Undefined.
1	-	-	-	Undefined.
2	-	-	-	Undefined.
3	Off	00	0	Expanded mode not selected.
	On	08	8	Expanded mode selected.
4	Off	00	0	Double-height mode not selected (height=1x).
	On	10	16	Double-height mode selected (height=2x).
5	Off	00	0	Double-width mode not selected (width=1x).
	On	20	32	Double-width mode selected (width=2x).
6	Off	00	0	Italic mode not selected.
	On	40	64	Italic mode selected.
7	Off	00	0	Underline mode not selected.
	On	80	128	Underline mode selected.

- [Notes]
- The printer can underline all characters, but cannot underline the spaces set by **HT**, **ESC \$**, **ESC ** and 90° rotated characters.
 - When characters are enlarged to different heights on one line, the characters are aligned at the baseline or topline (see **GS ~**).
 - This command resets the left and right margin at default

value (see **GS L**, **GS W**).

- **ESC E** can also be used to turn the emphasized mode on/off. However, the last-received setting command is the effective one.

- **ESC -** can also be used to turn the underlining mode on/off. However, the last-received setting command is the effective one.

- **ESC 4** can also be used to turn the italic mode on/off. However, the last-received setting command is the effective one.

- **GS !** can also be used to select character height/width. However, the last-received setting command is the effective one.

[Default] n = 0

[Reference] **ESC -, ESC E, ESC 4, GS !**

[Example]

ESC \$ nL nH

[Name] **Set absolute print position**

[Format]	ASCII	ESC \$	nL	nH
	Hex	1B 24	nL	nH
	Decimal	27 36	nL	nH

[Range] $0 \leq nL \leq 255$
 $0 \leq nH \leq 255$

[Description] Sets the distance from the beginning of the line to the position at which subsequent characters are to be printed.
 The distance from the beginning of the line to the print position is $[(nL + nH \times 256) \times (\text{vertical or horizontal motion unit})]$ inches.

[Notes]

- Settings outside the specified printable area are ignored.
- The horizontal and vertical motion unit are specified by **GS P**.
- **GS P** can change the horizontal (and vertical) motion unit. However, the value cannot be less than the minimum horizontal movement amount.
- In standard mode, the horizontal motion unit (x) is used.
- If the setting is outside the printing area width, it sets the absolute print position, but the left or right margin is set at default value.

3. PRINTER FUNCTIONS

[Default]

[Reference] **ESC \, GS P**

[Example]

ESC (v nL nH

[Name] Set relative vertical print position

[Format] ASCII ESC (v nL nH

Hex 1B 28 76 nL nH

Decimal 27 10 118 nL nH

[Range] $0 \leq nL \leq 255$

[Description] Sets the print vertical position based on the current position by using the horizontal or vertical motion unit.

- This command sets the distance from the current position to [(nL + nH x 256) x (horizontal or vertical motion unit)].

[Notes] •When the starting position is specified by N motion unit to the bottom:

$$nL + nH \times 256 = N$$

When the starting position is specified by N motion unit to the top (negative direction), use the complement of 65536:

$$nL + nH \times 256 = 65536 - N$$

[Default]

[Reference]

[Example]

ESC - n

[Name] **Turn underline mode on/off**

[Format] ASCII ESC - n

Hex 1B 2D n

Decimal 27 45 n

[Range] $0 \leq n \leq 2, 48 \leq n \leq 50$

[Description] Turns underline mode on or off, based on the following values of *n*:

n = 0, 48 Turns off underline mode

n = 1, 49 Turns on underline mode (1-dot thick)

n = 2, 50 Turns on underline mode (2-dot thick)

- [Notes]
- The printer can underline all characters, but cannot underline the space set by **HT** and right-side character spacing.
 - The printer cannot underline 90° rotated characters and white/black inverted characters.
 - When underline mode is turned off by setting the value of *n* to 0 or 48, the data which follows is not underlined.
 - Underline mode can also be turned on or off by using **ESC !**. Note, however, that the last received command is the effective one.

[Default] n=0

[Reference] **ESC !**

[Example]

ESC 0

[Name] **Select 1/8-inch line spacing**

[Format] ASCII ESC 0
Hex 1B 30
Decimal 27 48

[Description] Selects 1/8-inch line spacing

[Notes]

[Default]

[Reference] **ESC 2, ESC 3**

[Example]

ESC 2

[Name] **Select 1/6-inch line spacing**

[Format] ASCII ESC 2
Hex 1B 32
Decimal 27 50

[Description] Selects 1/6-inch line spacing.

[Notes]

[Default]

[Reference] **ESC 0, ESC 3**

[Example]

3. PRINTER FUNCTIONS

ESC 3 n

[Name]	Set line spacing
[Format]	ASCII ESC 3 n Hex 1B 33 n Decimal 27 51 n
[Range]	$0 \leq n \leq 255$
[Description]	Sets line spacing to [$n \times$ (vertical or horizontal motion unit)] inches.
[Notes]	<ul style="list-style-type: none">• The horizontal and vertical motion unit are specified by GS P. Changing the horizontal or vertical motion unit does not affect the current line spacing.• The GS P command can change the horizontal (and vertical) motion unit. However, the value cannot be less than the minimum vertical movement amount.• In standard mode, the vertical motion unit is used.• The maximum line spacing is $n = 255$ ($\cong 32\text{mm}$).
[Default]	$n = 32$ (1/6 inch)
[Reference]	ESC 0, ESC 2, GS P
[Example]	

ESC 4 n

[Name]	Set/reset italic mode
[Format]	ASCII ESC 4 n Hex 1B 34 n Decimal 27 52 n
[Range]	$0 \leq n \leq 1, 48 \leq n \leq 49$
[Description]	Turns italic mode on or off, based on the following values of n :

n	Function
0, 48	Turns off italic mode
1, 49	Turns on italic mode

[Notes]	<ul style="list-style-type: none">• The printer can print any character in italic mode.• When italic mode is turned off by setting the value of n to 0 or 48, the data which follows is printed in normal mode.
---------	---

3. PRINTER FUNCTIONS

- Italic mode can also be turned on or off using **ESC !**. Note, however, that the last received command is the effective one.

[Default] n = 0
[Reference] **ESC !**
[Example]

ESC = n

[Name] **Select peripheral device**
[Format] ASCII ESC = n
Hex 1B 3D n
Decimal 27 61 n
[Range] $0 \leq n \leq 255$
[Description] Select the device to which the host computer sends data, using *n* as follows:

Bit	Off/On	Hex	Decimal	Function
0	Off	00	0	Printer disabled
	On	01	1	Printer enabled
1	-	-	-	Undefined
2	-	-	-	Undefined
3	-	-	-	Undefined
4	-	-	-	Undefined
5	-	-	-	Undefined
6	-	-	-	Undefined
7	-	-	-	Undefined

[Notes] • When the printer is disabled, it ignores all transmitted data until the printer is enabled through this command.
[Default] n = 1
[Reference]
[Example]

ESC @

[Name] **Initialize printer**
[Format] ASCII ESC @
Hex 1B 40
Decimal 27 64

3. PRINTER FUNCTIONS

[Description] Clears the data in the print buffer and resets the printer mode to that in effect when power was turned on.

[Notes]

- The data in the receiver buffer is not cleared.
- The macro definitions are not cleared.

[Default]

[Reference]

[Example]

ESC D [n1...nk] NUL

[Name] **Set horizontal tab positions**

[Format]	ASCII	ESC	D	n1...nk	NUL
	Hex	1B	44	n1...nk	00
	Decimal	27	68	n1...nk	0

[Range] $1 \leq n \leq 255$

$0 \leq k \leq 32$

[Description] Sets horizontal tab positions

- n specifies the column number for setting a horizontal tab position calculated from the beginning of the line.
- k indicates the total number of horizontal tab positions to be set.

[Notes]

- The horizontal tab position is stored as a value of [character width x n] measured from the beginning of the line. The character width includes the right-side character spacing and double-width characters are set with twice the width of normal characters.
- This command cancels previous tab settings.
- When setting $n = 8$, the print position is moved to column 9, by sending **HT**.
- Up to 32 tab positions ($k = 32$) can be set. Data exceeding 32 tab positions is processed as normal data.
- Send [n] k in ascending order and place a 0 NUL code at the end. When [n] k is less than or equal to the preceding value [n] $k-1$, the setting is complete and the data which follows is processed as normal data.
- **ESC D NUL** cancels all horizontal tab positions.
- The previously specified horizontal tab position does not change, even if the character width is modified.

[Default] Default tab positions are set at intervals of 8 characters (col-

umns 9, 17, 25, ...) for Font A when the right-side character spacing is 0.

[Reference] **HT**

[Example]

ESC E n

[Name] **Turn emphasized mode on/off**

[Format] ASCII ESC E n

Hex 1B 45 n

Decimal 27 69 n

[Range] $0 \leq n \leq 255$

[Description] Turns emphasized mode on/off.

- When the LSB of n is 0, the emphasized mode is off.
- When the LSB of n is 1, the emphasized mode is on.

[Notes] • Only the LSB of n is effective.

- **ESC !** also turns on and off the emphasized mode. However, the last received command is the effective one.

[Default] $n = 0$

[Reference] **ESC !**

[Example]

ESC G n

[Name] **Turn double-strike mode on/off**

[Format] ASCII ESC G n

Hex 1B 47 n

Decimal 27 71 n

[Range] $0 \leq n \leq 255$

[Description] Turns double-strike mode on or off.

- When the LSB of n is 0, the double-strike mode is off.
- When the LSB of n is 1, the double-strike mode is on.

[Notes] • Only the LSB of n is effective.

- Printer output is the same in double-strike and emphasized mode.

[Default] $n = 0$

[Reference] **ESC E**

3. PRINTER FUNCTIONS

[Example]

ESC J n

[Name] **Print and paper feed**

[Format] ASCII ESC J n
Hex 1B 4A n
Decimal 27 74 n

[Range] $0 \leq n \leq 255$

[Description] Prints the data in the print buffer and feeds the paper [$n \times$ (vertical or horizontal motion unit)] inches.

[Notes]

- After printing has been completed, this command sets the print starting position to the beginning of the line.
- The paper feed amount set by this command does not affect the values set by **ESC 2** or **ESC 3**.
- The horizontal and vertical motion units are specified by **GS P**.
- **GS P** can change the vertical (and horizontal) motion unit. However, the value cannot be less than the minimum vertical movement amount.
- In standard mode, the vertical motion unit is used.
- The maximum paper feed amount is 31.8 mm.

[Default]

[Reference] **GS P**

[Example]

ESC R n

[Name] **Select an international character set**

[Format] ASCII ESC R n
Hex 1B 52 n
Decimal 27 82 n

[Range] $0 \leq n \leq 12$

[Description] Selects the international character set n according to the table below:

3. PRINTER FUNCTIONS

	Hex	23	24	40	5B	5C	5D	5E	60	7B	7C	7D	7E
n	Character set												
0	U.S.A.	#	\$	@	[\]	^	`	{		}	~
1	France	#	\$	à	°	ç	§	^	`	é	ù	è	"
2	Germany	#	\$	§	Ä	Ö	Ü	^	`	ä	ö	ü	β
3	United Kingdom	£	\$	@	[\]	^	`	{		}	~
4	Denmark I	#	\$	@	Æ	Ø	Å	^	`	æ	φ	å	~
5	Sweden	#	☒	É	Ä	Ö	Å	Ü	é	ä	ö	å	ü
6	Italy	#	\$	@	°	\	è	^	ù	à	ò	è	ì
7	Spain 1	Pt	\$	@	i	Ñ	¿	^	`	"	ñ	}	~
8	Japan	#	\$	@	[¥]	^	`	{		}	~
9	Norway	#	☒	É	Æ	Ø	Å	Ü	é	æ	φ	å	ü
10	Denmark II	#	\$	É	Æ	Ø	Å	Ü	é	æ	φ	å	ü
11	Spain 2	#	\$	à	i	Ñ	¿	é	'	í	ñ	ö	ü
12	South America	#	\$	à	i	Ñ	¿	é	ù	í	ñ	ö	ü

[Default] n = 0

[Reference]

[Example]

ESC \ nL nH

[Name] **Set relative print position**

[Format] ASCII ESC \ nL nH
 Hex 1B 5C nL nH
 Decimal 27 92 nL nH

[Range] $0 \leq nL \leq 255$
 $0 \leq nH \leq 255$

[Description] Sets the print starting position based on the current position by using the horizontal or vertical motion unit.
 Sets the distance from the current position to $[(nL + nH \times 256)]$

3. PRINTER FUNCTIONS

- × (horizontal or vertical motion unit)].
- [Notes]
- Any setting that exceeds the printable area is ignored.
 - When the starting position is specified by n motion units to the right:
 $nL + nH \times 256 = n$
 When the starting position is specified by n motion units to the left (negative direction), use the complement of 65536:
 $nL + nH \times 256 = 65536 - n$
 - If setting exceeds the printing area width, the left or right margin is set to the default value.
 - The horizontal and vertical motion unit are specified by **GS P**.
 - **GS P** can change the horizontal (and vertical) motion units. However, the value cannot be less than the minimum horizontal movement amount.
 - In standard mode, the horizontal motion unit is used.
- [Default]
- [Reference] **ESC \$, GS P**
- [Example]

ESC a n

- [Name] **Select justification**
- [Format]
- | | | | |
|---------|-----|----|---|
| ASCII | ESC | a | n |
| Hex | 1B | 61 | n |
| Decimal | 27 | 97 | n |
- [Range] $0 \leq n \leq 2, 48 \leq n \leq 50$
- [Description] Aligns all data in one line to the specified position. n selects the type of justification as follows:
- | n | Justification |
|-------|---------------|
| 0, 48 | Flush left |
| 1, 49 | Centered |
| 2, 50 | Flush right |
- [Notes]
- This command is only enabled when inserted at the beginning of a line.
 - Lines are justified within the specified printing area.
 - Spaces set by **HT**, **ESC \$** and **ESC ** will be justified according to the previously-entered mode.
- [Default] $n = 0$

[Reference]

[Example]

Flush left

Centered

Flush right

```
ABC
ABCD
ABCDE
```

```
ABC
ABCD
ABCDE
```

```
ABC
ABCD
ABCDE
```

ESC d n

[Name] **Print and feed paper *n* rows**

[Format]

ASCII	ESC	d	n
Hex	1B	64	n
Decimal	27	100	n

[Range] $0 \leq n \leq 200$

[Description] Prints the data in the print buffer and feeds the paper *n* rows.

[Notes]

- Sets the print starting position at the beginning of the line.
- This command does not affect the line spacing set by **ESC 2** or **ESC 3**.
- The maximum paper feed amount is 200 rows. Even if a paper feed amount of more than 200 rows is set, the printer feeds the paper only 200 rows.

[Default]

[Reference] **ESC 2, ESC 3**

[Example]

ESC r n

[Name] **Set/reset red printing mode**

[Format]

ASCII	ESC	r	n
Hex	1B	72	n
Decimal	27	114	n

[Range] $0 \leq n \leq 1, 48 \leq n \leq 49$

[Description] Sets and resets red printing mode.

n **Function**

0, 48 Reset red printing mode

1, 49 Set red printing mode

[Notes] • The printer prints only entire lines in red, not individual char-

3. PRINTER FUNCTIONS

acters.

- The printer prints red only if enabled (see Setup).

[Default]

$n = 0$

[Reference]

[Example]

ESC t n

[Name] **Select character code table**

[Format] ASCII ESC t n
Hex 1B 74 n
Decimal 27 116 n

[Range] $n = 0, 255$

[Description] Selects a page n from the character code table, as follows:

n	Page
0	0 (PC437 [U.S.A., Standard Europe])
255	Space page

[Notes]

[Default] $n = 0$

[Reference] See character code tables

[Example]

ESC v

[Name] **Transmit paper sensor status**

[Format] ASCII ESC v
Hex 1B 76
Decimal 27 118

[Description] When this command is received, transmit the current status of the paper sensor.

The status to be transmitted is shown in the table below:

3. PRINTER FUNCTIONS

Bit	Off/On	Hex	Decimal	Function
0,1	Off	00	0	Not used. Fixed to Off.
2,3	Off	00	0	Paper-end sensor: Paper present
	On	(0C)	(12)	Paper-end sensor: Paper not present
4	Off	00	0	Not used. Fixed to Off.
5	-	-	-	Undefined
6	-	-	-	Undefined
7	Off	00	0	Not used. Fixed to Off.

- [Notes]
- This command is executed immediately, even when the data buffer is full (Busy).
 - After the paper autoloader all buffers (receive and print) are cleared.

[Default]

[Reference] **DLE EOT**

[Example]

ESC x n

[Name] Selects speed/current mode

[Format] ASCII ESC x n

Hex 1B 78 n

Decimal 27 120 n

[Range] $0 \leq n \leq 2$

[Description] Selects printing speed/current mode.

n	Function
0	Low speed, low current
1	Normal mode
2	High speed, high current

[Notes]

[Default] n = 0

[Reference]

[Example]

3. PRINTER FUNCTIONS

ESC { n

[Name]	Turn upside-down printing mode on/off			
[Format]	ASCII	ESC	{	n
	Hex	1B	7B	n
	Decimal	27	123	n
[Range]	0 ≤ n ≤ 255			
[Description]	Turns upside-down printing mode on or off. <ul style="list-style-type: none"> • When the LSB of <i>n</i> is 0, the upside-down printing mode is off. • When the LSB of <i>n</i> is 1, the upside-down printing mode is on. 			
[Notes]	<ul style="list-style-type: none"> • Only the LSB of <i>n</i> is effective. • This command is valid only if entered at the beginning of a line. • In upside-down printing mode, the printer rotates the line to be printed 180° and then prints it. 			
[Default]	n = 0			
[Reference]				
[Example]				

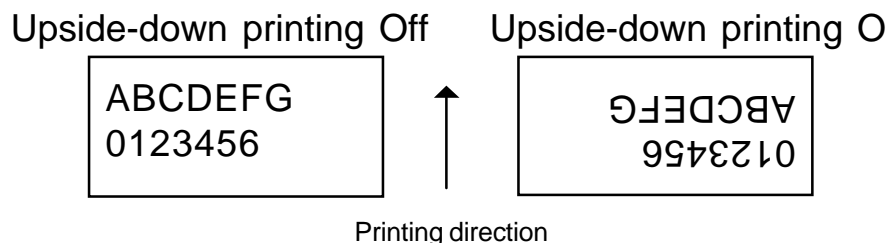

ESC · n xH xL yH yL

[Name]	Print logo (384 x 585 dots).						
[Format]	ASCII	ESC ·	n	xH	xL	yH	yL
	Hex	1B FA	n	xH	xL	yH	yL
	Decimal	27 250	n	xH	xL	yH	yL
[Range]	0 ≤ n ≤ 255						
	0 ≤ xH, xL, yH, yL ≤ 255						
[Description]	Prints graphic logo from flash. <i>xL</i> + <i>xH</i> × 256 specifies the starting dotline (1 ÷ 85). <i>yL</i> + <i>yH</i> × 256 specifies the number of lines to print.						
[Notes]	• If (<i>xL</i> + (<i>xH</i> × 256)) > 85 the printer does not execute the						

3. PRINTER FUNCTIONS

command.

- If ($xL + (xH \times 256) + yL + (yH \times 256)$) > 85 the printer prints only 85 - $xL + (xH \times 256) + 1$ dotline.

[Default]

[Reference]

[Example] To print from ram bank dotline 10 to dotline 64, send:
1BH FAH 00H 00H 0AH 00H 40H

GS ! n

[Name] **Select character size**

[Format]

ASCII	GS	!	n
Hex	1D	21	n
Decimal	29	33	n

[Range] $0 \leq n \leq 255$

[Description] Selects character height and width, as follows:

- Bits 0 to 3 low Nibble: to select character height (see table 2).
- Bits 4 to 7 High Nibble: to select character width (see table 1).

0bit	1bit	2bit	3bit	4bit	5bit	6bit	7bit
height				width			

Table 1 Select Character Width
(high Nibble)

Hex	Width
0x	1 (normal width = 1x)
1x	2 (width = 2x)
2x	3 (width = 3x)
3x-Fx	1 (normal width = 1x)

Table 2 Select character height
(Low Nibble)

Hex	Height
x0	1 (normal height = 1x)
x1	2 (height = 2x)
x2	3 (height = 3x)
x3-xF	1 (normal height = 1x)

[Notes]

- This command is effective for all characters (except HRI

3. PRINTER FUNCTIONS

characters).

- If n falls outside the defined range, this command is ignored.
- Characters enlarged to different heights on the same line are aligned at the baseline or topline (see **GS ~**).
- **ESC !** can also be used to select character size. However, the setting of the last received command is the effective one.

[Default] $n = 0$

[Reference] **ESC !**

[Example]

GS B n

[Name] **Turn white/black reverse printing mode on/off**

[Format] ASCII GS B n
Hex 1D 42 n
Decimal 29 66 n

[Range] $0 \leq n \leq 255$

[Description] Turns white/black reverse printing mode on or off.

- When the LSB of n is 0, white/black reverse printing is turned off.
- When the LSB of n is 1, white/black reverse printing is turned on.

[Notes]

- Only the LSB of n is effective.
- This command is available for both built-in and user-defined characters.
- This command does not affect bit image, downloaded bit image, bar code, HRI characters and spacing skipped by **HT**, **ESC \$** and **ESC **.
- This command does not affect white space between lines.
- White/black reverse mode has a higher priority than underline mode. Even if underline mode is on, it will be disabled (but not cancelled) when white/black reverse mode is selected.

[Default] $n = 0$

[Reference]

[Example]

GS I n

[Name]	Transmit printer ID			
[Format]	ASCII	GS	I	n
	Hex	1D	49	n
	Decimal	29	73	n
[Range]	1 ≤ n ≤ 3, 49 ≤ n ≤ 51			
[Description]	Transmits the printer ID specified by <i>n</i> follows:			

n	Printer ID	Specification
1, 49	Printer model ID	16H (TG35-58)
2, 50	Type ID	See table below
3, 51	ROM version ID	Depends on ROM version (4 character)

n = 2, Type ID

Bit	Off/On	Hex	Decimal	Function
0	Off	00	0	2-byte character codes not supported
1	Off	00	0	Autocutter not supplied
	On	02	2	Autocutter supplied
2	Off	00	0	Thermal paper w/o label
	On	04	4	Thermal paper w/label
3	-	-	-	Undefined
4	Off	00	0	Not used. Fixed to Off.
5	-	-	-	Undefined
6	-	-	-	Undefined
7	Off	00	0	Not used. Fixed to Off.

[Notes] • This command is executed when the data is processed in the data buffer. Therefore, there could be a time lag between command reception and data transmission, depending on data buffer status.

[Default]

[Reference]

[Example]

3. PRINTER FUNCTIONS

GS L nL nH

[Name]	Set left margin				
[Format]	ASCII	GS	L	nL	nH
	Hex	1D	4C	nL	nH
	Decimal	29	76	nL	nH
[Range]	0 ≤ nL, nH ≤ 255				
[Description]	Sets the left margin.				
	<ul style="list-style-type: none"> • The left margin is set to $[(nL + nH \times 256) \times (\text{horizontal motion unit})]$ inches. 				

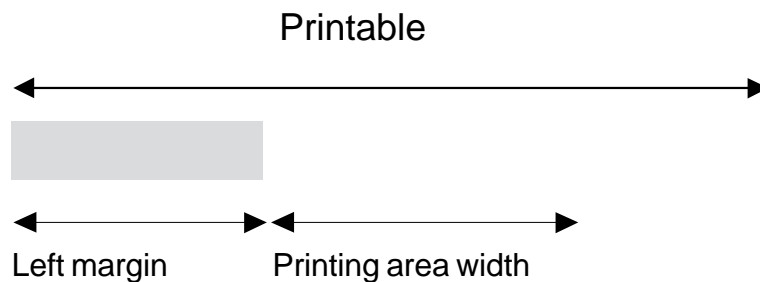

[Notes]	<ul style="list-style-type: none"> • This command is enabled only if set at the beginning of the line. • If the setting exceeds the printable area, the maximum value of the printable area is used. • If the left margin + printing area width is greater than the printable area, the printing area width is set at maximum value. • The horizontal and vertical motion unit are specified by GS P. Changing the horizontal or vertical motion unit does not affect the current left margin. • The GS P command can change the horizontal (and vertical) motion unit. • However, the value cannot be less than the minimum horizontal movement amount and it must be in even units of the minimum horizontal movement amount.
---------	---

[Default]	If font A :	nL = nH = 0
	If font B :	nL = 14 nH = 0

[Reference] **GS P, GS W**

[Example]

GS P x y

[Name]	Set horizontal and vertical motion units				
[Format]	ASCII	GS	P	x	y
	Hex	1D	50	x	y
	Decimal	29	80	x	y
[Range]	x = 100, 200 y = 100, 200				
[Description]	Sets the horizontal and vertical motion units to 1/x inch and 1/y inch respectively. When x is set to 0, the default setting value is used. When y is set to 0, the default setting value is used.				
[Notes]	<ul style="list-style-type: none"> • The horizontal direction is perpendicular to the paper feed direction. • In standard mode, the following commands use x or y, regardless of character rotation (upside-down or 90° clockwise rotation): <ul style="list-style-type: none"> ① Commands using x : ESC SP, ESC \$, ESC \, GS L, GS W. ② Commands using y : ESC 3, ESC J. • This command does not affect the previously specified values. • The calculated result from combining this command with others is truncated to the minimum value of the mechanical pitch or an exact multiple of that value. 				
[Default]	x = 200, y = 200				
[Reference]	ESC SP, ESC \$, ESC \, ESC 3, ESC J, GS L, GS W.				
[Example]					

GS W nL nH

[Name]	Set printing area width				
[Format]	ASCII	GS	W	nL	nH
	Hex	1D	57	nL	nH
	Decimal	29	87	nL	nH
[Range]	0 ≤ nL, nH ≤ 255				
[Description]	Sets the printing area width to the area specified by nL and nH. <ul style="list-style-type: none"> • The left margin is set to [(nL + nH × 256) × (horizontal mo- 				

3. PRINTER FUNCTIONS

tion unit)] inches.

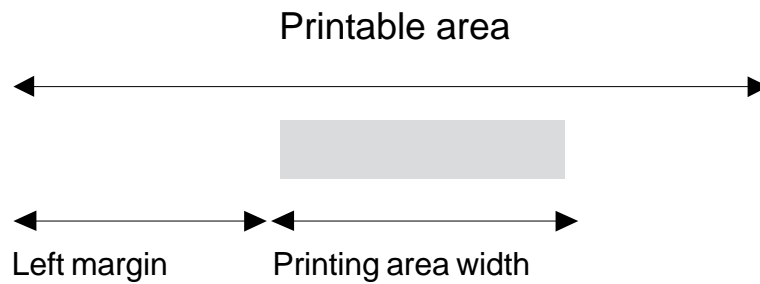

[Notes]

- This command is only enabled if set at the beginning of the line.
- If the right margin is greater than the printable area, the printing area width is set at maximum value.
- If the printing area width = 0, it is set at the maximum value.
- The horizontal and vertical motion units are specified by **GS P**. Changing the horizontal or vertical motion unit does not affect the current left margin.
- The **GS P** command can change the horizontal (and vertical) motion unit.
- However, the value cannot be less than the minimum horizontal movement amount and it must be in even units of the minimum horizontal movement amount.

[Default]

If font A : nL = 192 nH = 1
If font B : nL = 164 nH = 1

[Reference]

GS L, GS P

[Example]

GS Y n

[Name]

Sets height in printing.

[Format]

ASCII GS Y n
Hex 1D 59 n
Decimal 29 89 n

[Description]

Sets height during printing based on following values of n:
When you print a dot line if
n=0 height is set to one
n ≠ 0 (default value) height is set to two

[Notes]

When n ≠ 0 (default value) each dotline is twice replicated

[Default] $n \neq 0$

[Reference]

[Example]

GS Z n

[Name] Receive n bytes from serial port

[Format] ASCII GS Z n

Hex 1D 5A n

Decimal 27 90 n

[Description] Receives n bytes from serial port and prints them in graphic mode

[Notes] Max value of n is 58

[Default]

[Reference]

[Example]

GS r n

[Name] **Transmit status**

[Format] ASCII GS r n

Hex 1D 72 n

Decimal 29 114 n

[Range] $n = 1, 2, 49, 50$

[Description] Transmits the status specified by n as follows:

n Function

1, 49 Transmits paper sensor status (as for **ESC v**).

2, 50 Transmits connector drawer status.

3. PRINTER FUNCTIONS

Paper sensor status (n = 1, 49)

Bit	Off/On	Hex	Decimal	Function
0,1	Off	00	0	Not used. Fixed to Off.
2,3	Off	00	0	Paper-end sensor: Paper present
	On	(0C)	(12)	Paper-end sensor: Paper not present
4	Off	00	0	Not used. Fixed to Off.
5	-	-	-	Undefined
6	-	-	-	Undefined
7	Off	00	0	Not used. Fixed to Off.

Connector drawer status (n = 2, 50)

Bit	Off/On	Hex	Decimal	Function
0	Off	00	0	Pin 3 low level
	On	01	1	Pin 3 high level
1	-	-	-	Undefined
2	-	-	-	Undefined
3	-	-	-	Undefined
4	Off	00	0	Not used. Fixed to Off.
5	-	-	-	Undefined
6	-	-	-	Undefined
7	Off	00	0	Not used. Fixed to Off.

[Notes]

- This command is executed when the data is processed in the data buffer. Therefore, there may be a time lag between receiving the command and transmitting the status, depending on data buffer status.

[Default]

[Reference]

DLE EOT, ESC v

[Example]

GS | n

[Name] **Set printing density**

[Format] ASCII GS | n
 Hex 1D 7C n
 Decimal 29 124 n

[Range] $0 \leq n \leq 4, 48 \leq n \leq 52$

[Description] Sets printing density.

n specifies printing density as follows:

n	Printing density
0, 48	Very light
1, 49	Light
2, 50	Normal
3, 51	Dark
4, 52	Very dark

[Notes] • Printing density reverts to the default value when the printer is reset or turned off.

[Default] $n = 2$

[Reference]

[Example]

4. TECHNICAL DATA

4.1 TECHNICAL DATA

Table 4.1 lists the main technical features of the printer.

(Tab.4.1)

Model	TG35-T	TG58-T
Resolution	200 DPI (8 dot/mm)	
Printing speed	42 mm/sec.	
Paper feed speed	60 mm/sec.	
Paper roll dimensions	35 mm	58 mm
Standard interfaces	TTL Serial	
Optional interfaces	RS232 Serial	
Power supply	12 Vdc +/- 10%	
Absorption		
Current in printing	1.5 A	
Current in stand by	0.5 A	
Environmental conditions		
Operating temperature	0 °C - 50 °C	
Relative humidity	20% - 85%	
Storage temperature / Humidity	-25°C +70°C / 10% - 80%	
Options	RS232 cable adaptation	

4.2 DIMENSIONS

The Figure 4.1 illustrates the overall dimensions for the TG35/58-T printer.

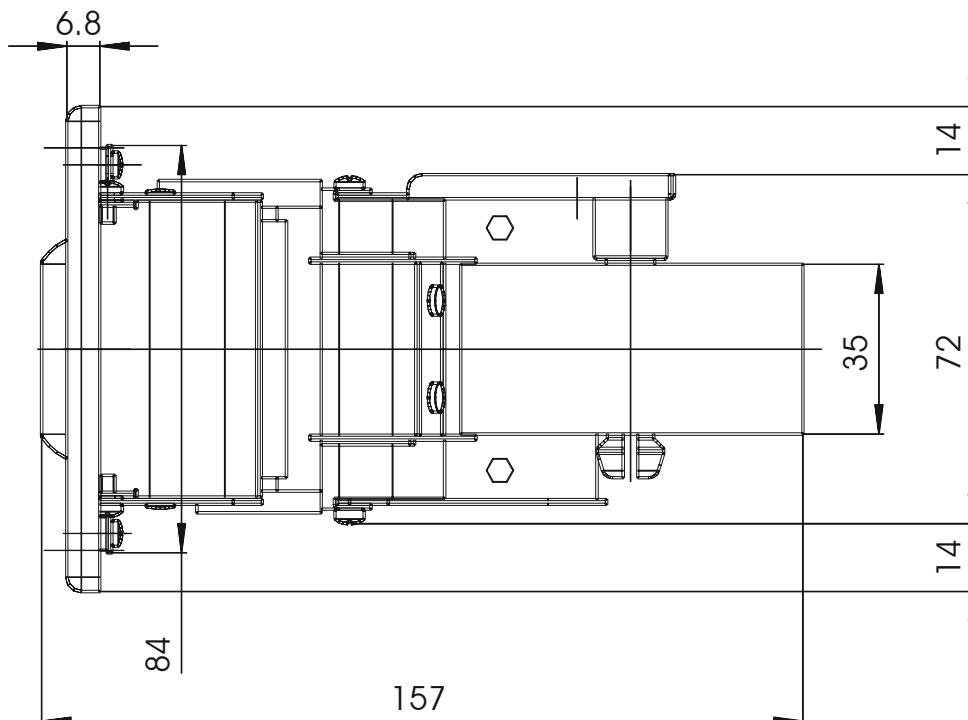
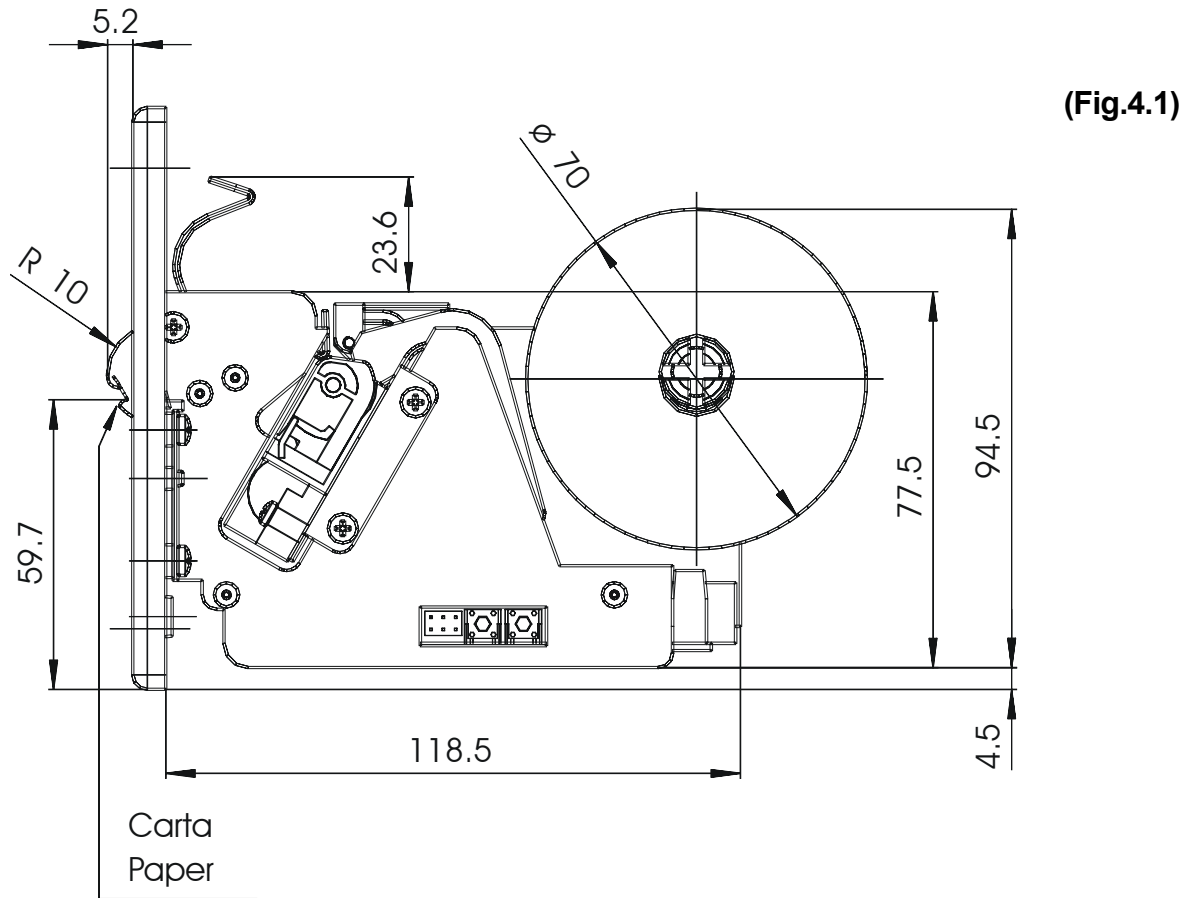

4. TECHNICAL DATA

The Figures 4.2 and 4.3 illustrates the overall dimensions for the frontal panel of TG35-T and TG58-T printer.

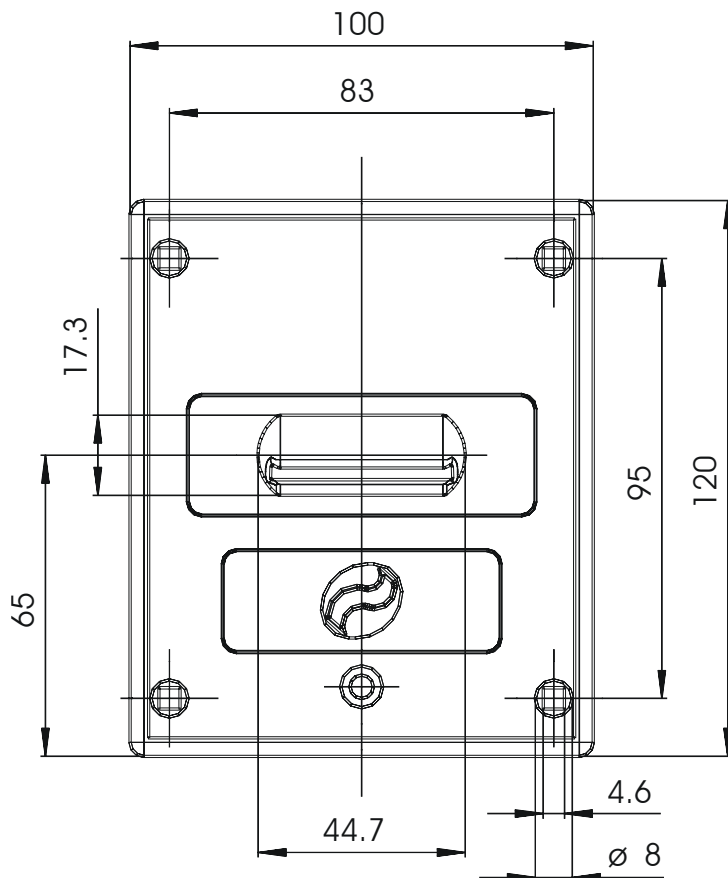

(Fig.4.2)

TG35-T frontal panel

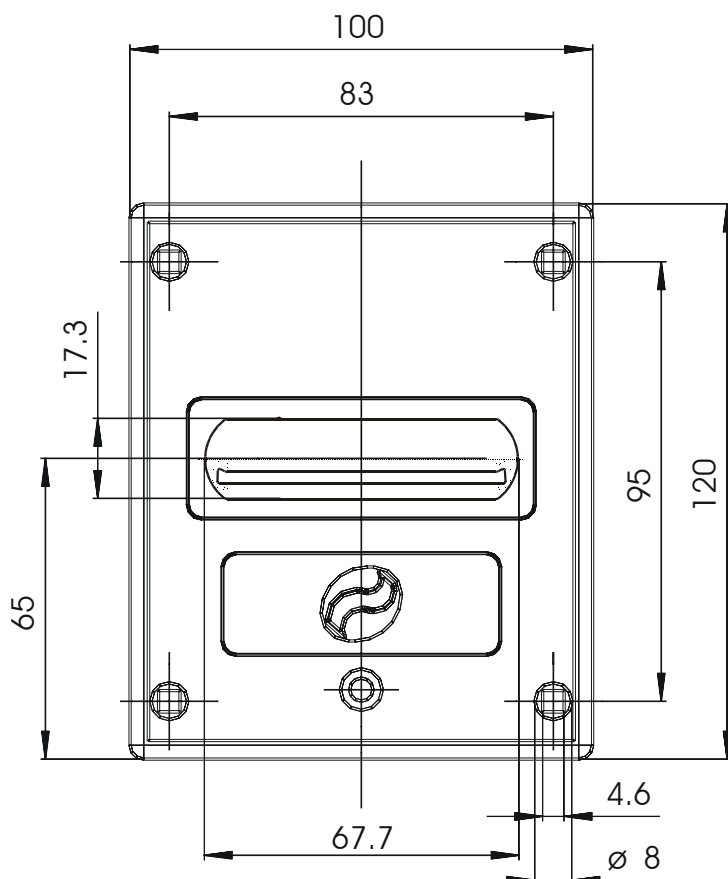

(Fig.4.3)

TG58-T frontal panel

A.1 ACCESSORIES

A.1.1 Power supply

The following figure shows the 12V power supply, manufactured by Custom Engineering, that can be used to operate the TG35/58-T printer.

(Fig.A.1)

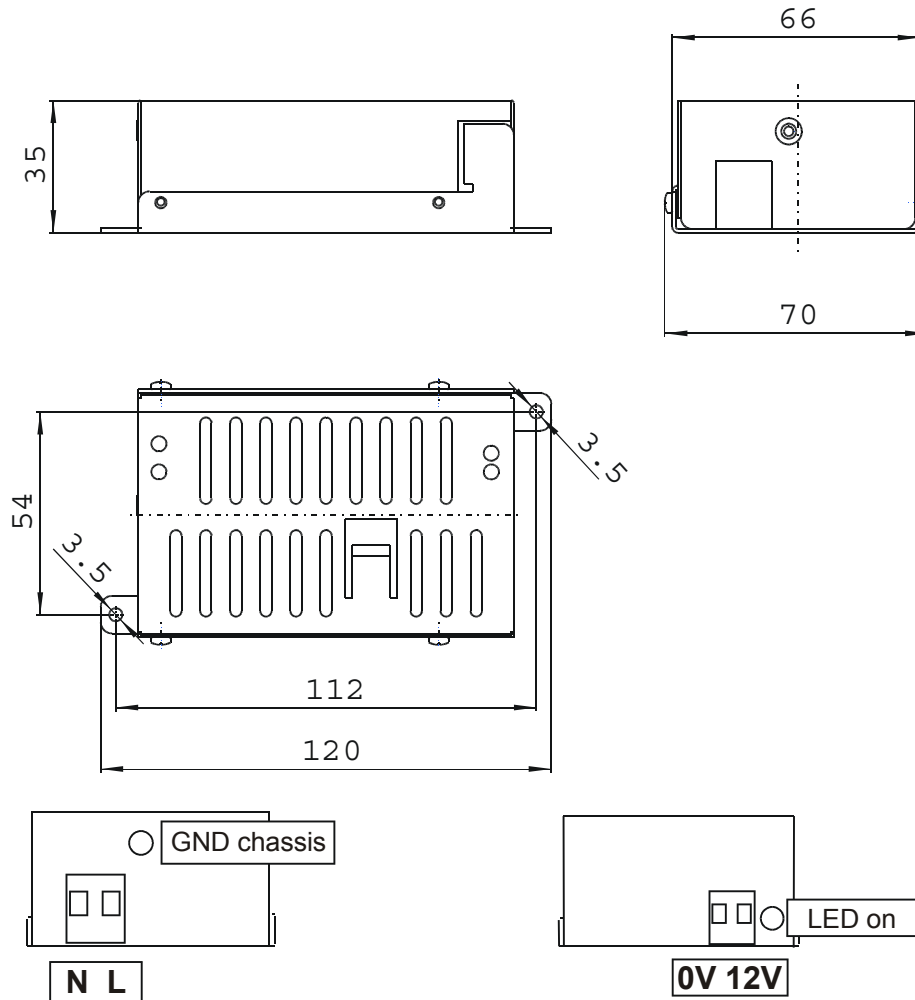

(Tab.A.1)

Input specifications

Input voltage	100 Vac to 240 Vac
Input frequency	50 Hz to 60 Hz

Output specifications

Output voltage	12 V	
Output current	Maximum	4 A
	Peak	6 A
	Short Circuit	6 A

A.1.2 RS232 cable adaptation

There is an optional RS232 cable adaptation available for the printer that consists in a double connection system (fig. A.2). On one side is a 9-pin female connector for the serial port; on the other side of the same cable is a RJ45 connector.

(Fig.A.2)

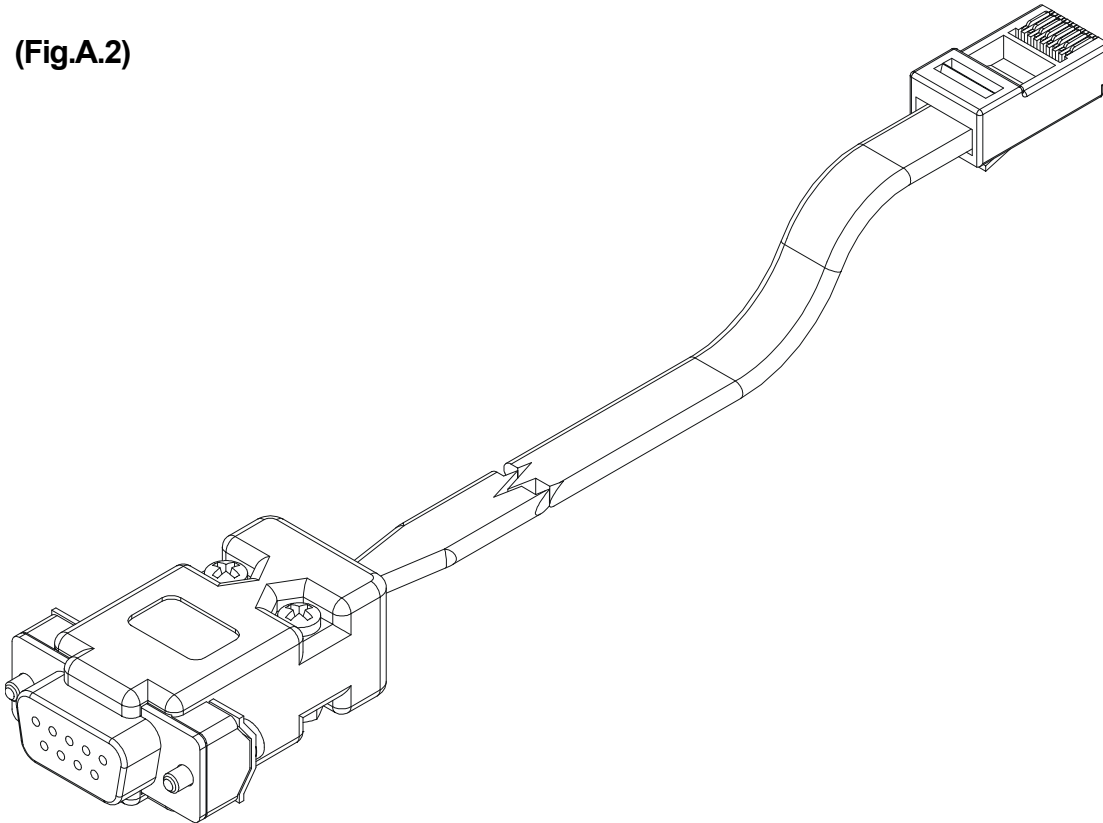

To connect the printer with the RS232 interface use this connection cable and proceed as follows:

- connect the cable RJ45 connector to the J9 connector located at the back of the printer (see fig. A.3);
- connect the 9-pin female connector (fig. A.3) to the serial port.

(Fig.A.3)

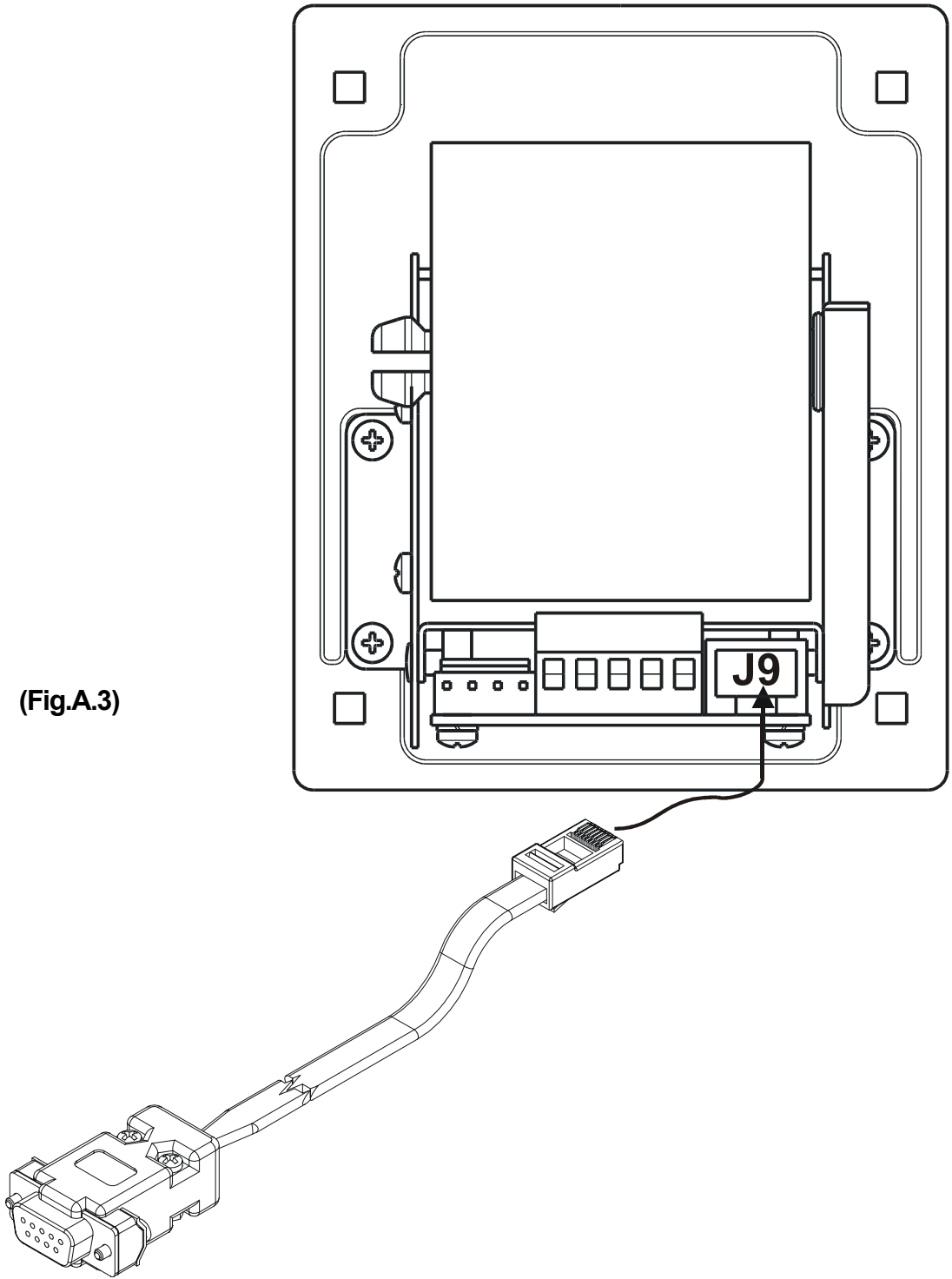

ATTACHMENT A - ACCESSORIES AND SPARE PARTS

For the layout of signals on the connectors, please refer to tables A.2 and A.3.

RJ45 cable connector (fig. A.3)

(Tab.A.2)

PIN	SIGNAL	IN / OUT	DESCRIPTION
1	VCC	OUT	+ 5V
2	GND	-	GROUND
3	TXD	OUT	DATA TRANSMISSION
4	RXD	IN	DATA RECEPTION
5	RTS	OUT	READY TO SEND
6	+VIN	OUT	+ 12V
7	NC	-	NOT CONNECTED
8	NC	-	NOT CONNECTED

9-pin female cable connector (fig. A.3)

(Tab.A.3)

PIN	SIGNAL PRINTER	DESCRIPTION	IN/OUT	SIGNAL HOST SIDE
1	DCD	Data Carrier detect Printer On (active at RS232 level high)	OUT	DCD
2	TX	Data Transmission Serial output (Printer side)	OUT	RX
3	RX	Data Reception Serial input (Printer side)	IN	TX
4	N.C.	Not connected	-	N.C.
5	GND	Ground	-	GND
6	DTR	Data Terminal Ready. Printer on and functioning (active at RS232 level hig)	OUT	DSR
7	N.C.	Not connected	-	N.C.
8	RTS	Ready to send. Ready for data transmission (active at RS232 level high)	OUT	CTS
9	N.C.	Not connected	-	N.C.

ATTACHMENT A - ACCESSORIES AND SPARE PARTS

NOTE: In the table fig. A.3 Description and IN/OUT columns always are related to signal printer

A.2 SPARE PARTS

RCT35X70-AF	Thermal roll paper fraud preventing	(Tab.A.4)
--------------------	-------------------------------------	-----------

RCT35X70-RS	Thermal roll paper back side pre-printed	(Tab.A.5)
	Customized pre-printed logo for 2000 rolls order minimum	